

10 CONSTANT

VOLUME

CEILING

DIFFUSERS

APPLICATIONS

- COOLING & HEATING
- PROPORTIONAL TERMINAL RE-HEAT
- STAND ALONE OR BMS CONTROLS

ADVANTAGES

- VERSATILE
- VALUE FOR MONEY
- TERMINAL HEATING OPTION
- HEATING CONTROL OPTIONS
- EASY TO INSTALL
- NO REGULAR MAINTENANCE

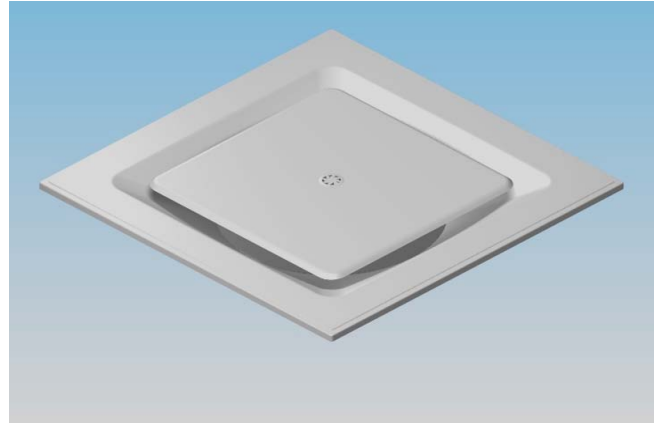

CSD

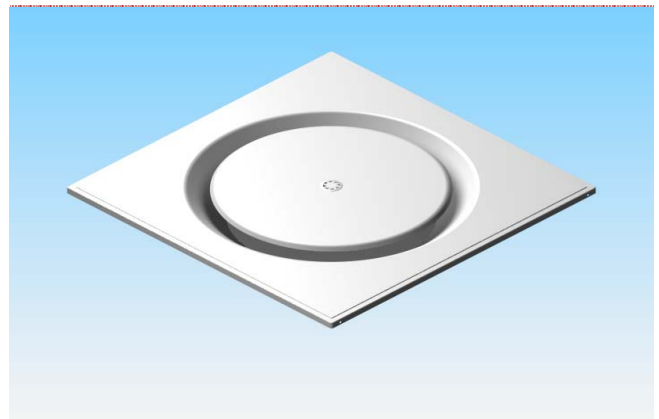

CCD



CRD

VARI-DISC CONSTANT VOLUME CEILING DIFFUSER PERFORMANCE CSD - CCD - CRD

SIZE	READING	NECK TOTAL PRESSURE (Pa)								
		20	30	40	50	60	70	80	90	100
150	FLOW l/s	63	77	88	99	108	117	125	133	140
	THROW m	2.0	2.1	2.7	3.0	3.3	3.5	3.7	4.0	4.2
	NC LEVEL	-	-	-	-	26	28	31	33	35
200	FLOW l/s	96	118	137	153	169	184	195	207	218
	THROW m	2.0	2.6	3.0	3.2	3.6	3.9	4.2	4.5	4.7
	NC LEVEL	-	27	28	29	30	33	36	38	40
250	FLOW l/s	140	171	198	221	242	261	279	296	313
	THROW m	2.4	2.6	3.2	3.5	3.9	4.2	4.5	4.7	5.1
	NC LEVEL	-	27	29	31	33	36	38	40	42
300	FLOW l/s	176	216	250	280	307	332	355	377	398
	THROW m	2.5	2.8	3.3	3.7	4.2	4.6	4.8	5.2	5.4
	NC LEVEL	27	28	30	32	35	37	39	4.1	43
350	FLOW l/s	246	301	349	389	426	461	492	523	551
	THROW m	2.7	3.2	3.6	4.1	4.5	5.0	5.5	5.7	5.9
	NC LEVEL	27	28	30	32	35	38	40	43	45

Throw data is taken 25mm below the ceiling on a line through the centre of the diffuser with the control disc fully open & an air velocity is at 0.25m/s.

Noise criteria levels apply to a single diffuser mounted in a room having a Sound Absorption of 10dB in octave bands having centre frequencies from 125Hz to 8000Hz (i.e. the difference between Sound Pressure Level (dB re: 10^{-6} Pa) and Sound Pressure Level (dB re: 10^{-12} Pa) is equal to 10dB). These levels represent only the noise generated by the diffuser and do not take into account any duct-borne noise.

Diffusers are factory set for a minimum of 30% of the maximum flow levels reflected above. It should be noted that minimum air flow settings are approximate & may require to be reset on site to compensate for actual site system pressures.

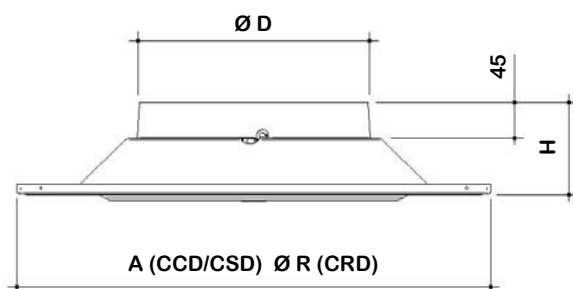

CCD/CSD/CRD DIFFUSER DIMENSIONS

DIMENSIONS (mm)				
NOMINAL SIZE	Ø D	A	H	Ø R
150	153	495 x 495 595 x 595	116	580
200	200	495 x 495 595 x 595	116	580
250	250	495 x 495 595 x 595	116	580
300	293	495 x 495 595 x 595	116	580
350	346	595 x 595	116	580

ADDITIONAL INFORMATION CCD DIFFUSERS

INTRODUCTION

The RICKARD Constant Volume Ceiling Diffusers (CCD/CSD/CRD) are primarily intended for use in internal zones of a building where uniform radial discharge is the most suitable supply air pattern. Normally these zones are less complex to air-condition as load fluctuations are not as severe as those on the perimeter. The CCD/CSD/CRD, as their names imply, do not automatically regulate the air volume entering the conditioned space - they are constant volume devices. Consequently, room temperatures will vary with room loads (assuming the duct air temperature and pressure remain constant). This temperature fluctuation may be countered by using the CCD/CSD/CRD fitted with a neck mounted re-heater or in conjunction with our TCD-E/H and proportional - integral volume / heater control to provide a measure of variable volume and / or reheat. Should this method be decided upon, care should be taken in selection of the CCD/CSD/CRD diffusers to ensure dumping does not take place at minimum air flow status.

The CCD/CSD are supplied to fit any ceiling layout from 500mm square to 600mm x 1200mm. Diffusers for baffled ceilings are also produced. Section details of how the diffusers can be installed in various suspended and plastered ceiling styles are shown later in this catalogue.

Normally the RICKARD CCD/CSD diffusers are laid into and entirely supported by the suspended ceiling tees, although suspension points may be provided should these be deemed necessary. A variety of diffuser edge profiles are available to adapt to the different ceilings used: - exposed tee shadow-line; exposed tee drop-in; concealed tee and plastered ceiling types. None of these mounting features for the various styles are visible from below, nor do they interrupt the ceiling layout in any way. Details of the various edgings are as sections through diffusers showing both ceiling tees and tiles.

All diffusers have a steel construction and are finished in a chip resistant baked epoxy powder coating which is available in a wide range of colours to suit architectural requirements.

SELECTING THE CCD /CSD/ CRD DIFFUSERS

The most important practical factors to consider in internal zones are noise levels and uniform air distribution without "dumping" or "coning" effects. "Dumping" is the tendency for cold, dense air to leave the diffusers as a vertical column similar to a waterfall. The effect of dumping is to overcool the person immediately below the diffuser while the person fur-

ther away will not be cooled enough. Dumping is eliminated by ensuring that the discharge air energy from the diffuser is adequate to distribute conditioned air evenly throughout the conditioned area and at the same time provide good secondary room air induction rates. Providing the total pressure in the neck of the RICKARD CCD diffuser selected is not too low, dumping of conditioned cold air will not take place.

In the context of radial discharge ceiling diffusers, 'coning' occurs when two air streams travelling in opposite directions meet. As a result a downward moving cone of air is produced which will have a similar effect to dumping. Coning is avoided by ensuring that diffusers are placed far enough apart to eliminate drafts in the conditioned space. The table on the previous page shows the distance from the various diffusers at which air velocity has reduced to 0.25 m/s (50 ft/min) (the 'throw' of the diffuser). Using this information, diffusers should be situated in the ceiling such that two adjacent diffusers are separated by slightly less than the sum of their throws. Exactly how much less depends largely on the ceiling height and the amount of air movement desired in the conditioned space. If the CCD is used in conjunction with Variable Linear Diffusers or Side Wall VAV Units, their throws should also be considered.

SELECTING THE CCD /CSD /CRD DIFFUSERS

Although the CCD is a constant volume terminal, the air volume may be adjusted manually to obtain the required design air flow. This is achieved by pulling the control disc up or down manually on the ratchet provided on the bayonet fitting.

If required, the volume control disc may be locked in this position by means of a locknut on the control shaft (locknut optional extra).

This adjustment is slightly more complicated when the diffuser is fitted with electric heating and a room temperature sensor and heat shield is installed. The purpose of the heat shield is to shield the room temperature sensor located above the slots in the trim disc from radiation emitted by the heater elements in the neck of the diffuser. This shield must first be removed by loosening the brass nut to expose the adjustment knob. The heat shield must then be replaced to ensure proper temperature control.

CEILING DIFFUSER DIRECTIONAL BLOW OPTIONS

Supply air directional blanking for RICKARD VCD, VSD & VRD ceiling diffusers is achieved with the use of simple blanking plates. These blanking plates are fixed to the diffuser trim plate and are available in 90° and 180° curved form for the various neck sizes. As shown 270° Three-way blow, 180° Two-way blow or opposite side Two-way blow can be achieved using different configurations of blanking plates. Please note that throw data presented in the catalogue will no longer be valid when blanking plates are

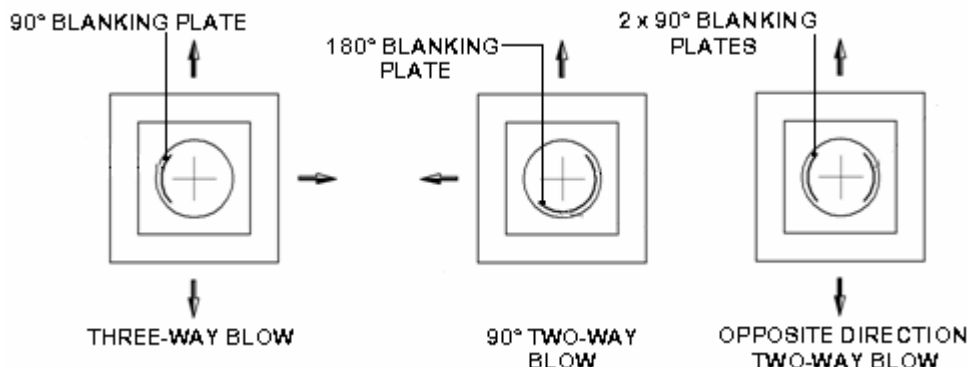

ELECTRIC HEATING

The RICKARD CSD/CCD/CRD ceiling diffusers may be fitted with electric re-heaters housed within a sleeve which slides into the standard diffuser neck. Heater elements used in the diffusers are “black heat” having a heat density of 3.2W/cm² and are of the stainless steel sheathed type, rated for 110, 208, 230 or 277 Volts. In all cases an auto-reset 65°±5°C cut-out is fitted. A power-reset 85°C±5°C overheat safety cutout may be fitted on request. The “power reset” type is reset by turning the power supply off momentarily. Push-button type manual reset safeties are not recommended in conjunction with diffuser re-heaters.

For additional safety, RICKARD are able to offer an **Airflow Switch** to interrupt power to the re-heater controls when there is insufficient airflow across the heater element.

Heaters are available in various capacities, ranging from 0.5kW to 2.5kW. When calculating heater capacities for CAV diffusers, care must be taken to ensure that an excessive supply air temperature rise in the diffuser is avoided. Discharge temperatures in excess of than 32°C are likely to cause stratification within the room. As a guide-line, the temperature of the air leaving the diffuser should not be more than 10°C above actual room temperature. Kindly refer to the following table giving the maximum recommended heater / size able to fit within the heater sleeve for each diffuser neck size. Heater output ratings may be adjusted electronically for an air temperature rise up to those quoted in the following table, a standard feature of the RICKARD **MLM**, **Mini BMS** and **Interoperable BMS Compatible Controls**.

IMPORTANT: These maximum capacities do not take into account limitations of the triac which is rated at 12A maximum. This reduces the capacity of the triac at low voltage supply .

HEATER CONTROL

For accurate control of room temperature, the electric re-heater is controlled on a step-less, proportional-integral ba-

sis. In addition to having a proportional-integral output signal for cooling control, the temperature controller also has a proportional-integral output signal for heating. This is done by means of a triac switching set (current valve) which varies the heater output capacity by cycling the power supply to the heater on and off – Pulse Width Modulation (PWM). This switching takes place over a cycle of approximately 2 seconds and always occurs at zero voltage to avoid radio frequency interference and voltage spikes. The “on” and “off” periods are varied in proportion to the amount of heating required, i.e., a required heating capacity of 75% will result in an “on” period of 1.5 seconds and an “off” period of 0.5 seconds.

In a situation where multiple diffusers are controlled from a single controller, each diffuser will be fitted with its own triac set that will receive a heating signal from the Master controller. The heating signal transmitted by the controller is a 9 Volt DC signal.

From the table “Maximum Heater Output & Capacities” in the right hand column of the previous page, it will be noted that for each neck total pressure there is a specific heater output quoted and for each diffuser size a standard heater capacity is referenced. For example, in the case of a VCD 250 diffuser, the re-heater sleeve would be factory fitted with a 2000 watt heater, which by utilizing the RICKARD **MLM**, **Mini BMS** or **Interoperable BMS Compatible Controls**, can be electronically set for any output from as little as 100 watts to 2000 watts to match the design engineer’s requirements for minimum cooling mode supply air flow and desired leaving air temperature. Therefore, if the diffuser neck total pressure were to be set at 50Pa and the minimum desired minimum air flow was 30% of maximum with 17°C air temperature rise, the heater output for a VCD 250 required would be 1350 watts, set by using a computer for the **MLM**, **Mini BMS** or **Interoperable BMS Compatible Controls**. Kindly refer to Section 11 of this catalogue for more detailed information.

MAXIMUM HEATER OUTPUT & AIR TEMPERATURE RISE DATA

NECK TOTAL PRESSURE (Pa)	20	30	40	50	60	70	80	90	100	FITTED HEATER CAPACITY (WATTS)
NOMINAL SIZE	TEMPERATURE RISE AT RATED MAXIMUM DIFFUSER AIR FLOW (°C)									
150	8.01	6.51	5.63	5.04	4.60	4.25	3.98	3.77	3.57	750
200	11.57	9.47	8.12	7.23	6.58	6.10	5.68	5.37	5.08	1500
250	11.42	9.31	8.09	7.22	6.59	6.11	5.71	5.38	5.11	2000
300	11.38	9.26	8.01	7.16	6.53	6.04	5.65	5.31	5.04	2500
350	8.01	6.53	5.65	5.04	4.60	4.25	3.98	3.75	3.55	2500

SAMPLE SPECIFICATION

Supply and install where indicated on the engineering drawings Rickard type CCD/CSD (CRD) constant volume square (round) Ceiling Diffusers to provide horizontal throw, high induction supply air. Connection to the diffusers shall be vertical entry through a seamless backpan having a circular inlet collar. The diffusers shall incorporate an air volume balancing damper adjustable from below the ceiling through a port, which shall be concealed by means of removable colour keyed cap. Each diffuser is to be finished in a textured semi-matt white chip resistant fused epoxy coating.

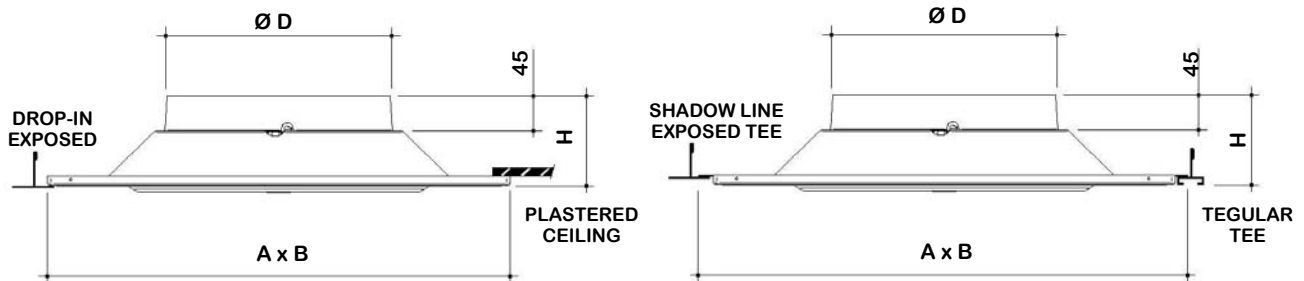
DIMENSIONS AND METHODS OF MOUNTING
SQUARE CCD & CSD DIFFUSERS

NOMINAL DIFFUSER SIZE	Ø D (mm)	A x B (mm)	H (mm)
150	150	495 x 495 595 x 595	116
200	200	495 x 495 595 x 595	116
250	250	495 x 495 595 x 595	116
300	293	495 x 495 595 x 595	116
350	346	595 x 595	116

CIRCULAR CRD DIFFUSER DIMENSIONS

NOMINAL SIZE	D (mm)	H (mm)	R (mm)	T (mm)
150	150	116	580	471
200	200	116	580	471
250	250	116	580	471
300	293	116	580	471
350	346	116	580	552

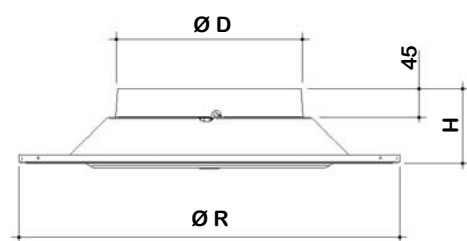
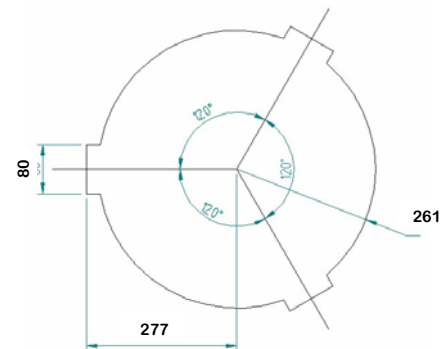
CRD THREE-POINT FIXING CLIPS

CRD THREE-POINT FIXING CUTOUT TEMPLATE

RICKARD AIR DIFFUSION (PTY) LTD RESERVES THE RIGHT TO CHANGE SPECIFICATIONS AND DATA WITHOUT PRIOR NOTICE.